

INSTALLATION NOTE

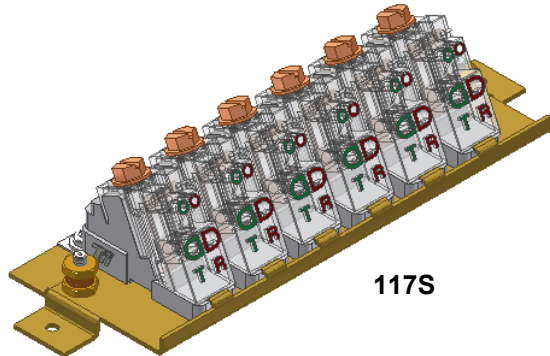

117S

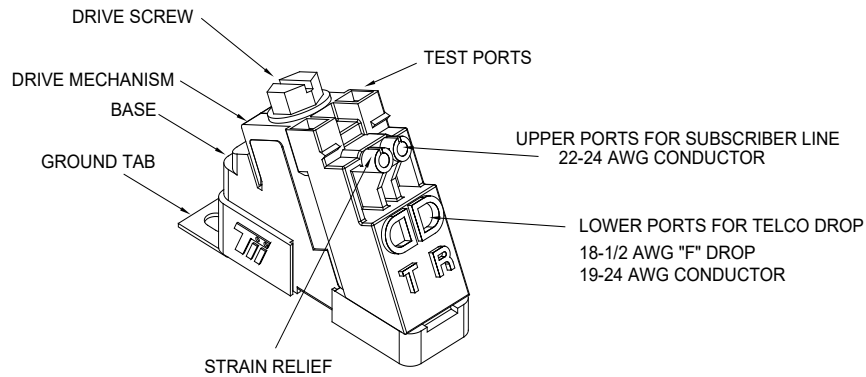

Figure 2

CAUTION: The Product shall be installed in a manner to comply with applicable national and local safety codes.

ATTENTION : Le produit doit être installé de manière à se conformer aux réglementations nationales et locales applicables en matière de sécurité.

SAFETY: Verify no hazardous voltages exist on lines while making connections.

SÉCURITÉ : Vérifiez qu'aucunes tensions dangereuses existent sur les lignes lors des connexions.

1. General

1.1 This installation note covers the description and installation of the tii Series 117S six line modular adapter plate with six AD-01G-FS modules.

1.2 The AD-01G-FS module's consist of a tii heavy duty electrode gas tube surge arrester, failshort device and Gel-Sealed IDC type connectors for terminating all wires in one completely self contained unit.

1.3 **National Electric Code Requirements:** The protector panel shall be installed per National Electric Code ANSI/NFPA 70, Article 800, Section C, and shall meet all other applicable local safety codes.

2. Warranty

See Tii Warranty. If this unit fails during the warranty period, the factory should be requested to authorize return. Return the unit prepaid. Units that fail due to normal wear or abuse should be discarded.

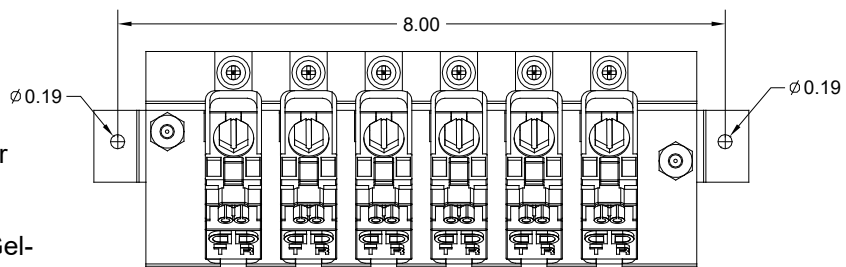

Figure 1

3. Installation

3.1 Remove the tii 117S from the plastic bag and inspect for damage; if damaged, replace it with an undamaged tii 117S.

3.2 Using the (2) mounting holes on the 117S plate secure to applicable surface using 10-32 hardware (See Figure 1).

3.3 The unit shall be used in a Listed, primary telephone protector enclosure or metal enclosure that has been tested for the applicable environment.

4. Wiring

4.1 The two upper ports of the Angle Driver are intended to terminate subscriber (customer) wires. Telco drop (feeder)

wires must be terminated in the two lower ports of the Angle Driver.

4.2 Upper Port Subscriber Connections (see Figure 3)
Subscriber terminations are already made in the factory. If it is necessary to re-terminate a subscriber wire, do so as follows:

- Do not strip wire insulation. Make certain wire ends are cut flush with insulation.
- Unscrew Angle Driver screw to the full upright position.
- Fully insert the two subscriber wires into their respective tip and ring (color-coded) ports.
- Dress the wires through the strain relief slots to hold them in place (see Figure 3).

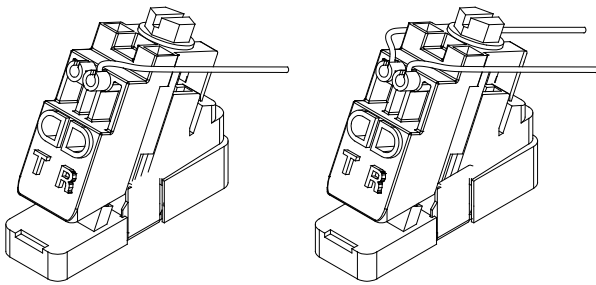

Figure 3

4.3 Lower Port Telco Connections (see Figure 4)

- Do not strip wire insulation. Make certain wire ends are cut flush with insulation.
- Unscrew Angle Driver screw to full upright position.
- Fully insert the two feeder (telco) wires into their respective tip and ring (color-coded) ports.
- While holding the two telco wires in place tighten Drive Screw to full down position.

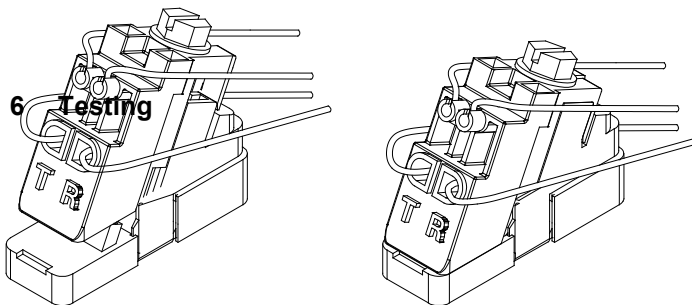

Figure 4

Feeder and subscriber wires must be segregated between the upper and lower ports to facilitate isolation testing (Figure 5).

6.1 Upper and Lower Port Connected

- With Driver in the fully closed position, insert test clips into tip/ring test port access holes located at top of driver. Perform customary tests.

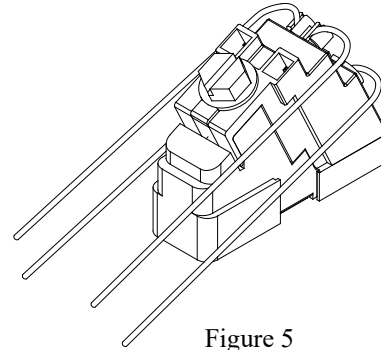

Figure 5

6.2 Testing Subscriber Connections (see Figure 6)

- Loosen drive screw so driver is in the full upright position.
- Remove telco wires from lower ports of driver.
- Tighten drive screw so driver is in the full down position.
- With Driver in the fully closed position, insert test clips into tip/ring test port access holes located at top of driver. Perform customary tests.

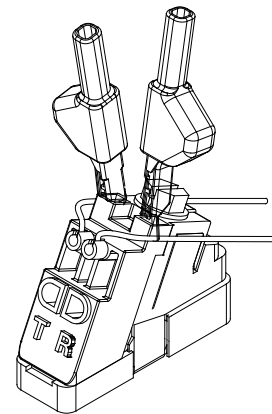

Figure 6