

**Warranty:** If this unit fails during the warranty period, contact tii customer service to authorize return. Unit may be returned prepaid.

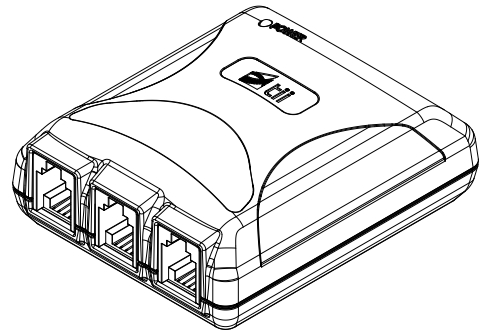

141 Rodeo Drive  
Edgewood, NY 11717  
Toll Free 888.444.4720  
www.tiinettech.com



Model VIS-3  
**VOICE INTERCOM SWITCH**

## Installation Note

### Description

1. The tii VIS-3 (Voice Intercom Switch) is a microprocessor controlled module that provides seamless switching from Digital Voice Service to Door Answering Systems (DAS)/Intercom service in multiple dwelling unit's (MDU's).
2. The tii VIS-3 enables attending to the DAS/Intercom calls while using Digital Voice Service. The VIS-3 provides call waiting type functionality between the two services.
3. The tii VIS-3 is for indoor use only.
4. The tii VIS-3 switches to the DAS/Intercom when the Digital Voice Service loses power.
5. The tii VIS-3 provides line hold function while answering the DAS intercom.

### Installation

1. Locate a suitable flat, dry area to install the unit.
2. The existing telephone wiring to the MDU may need to be modified to enable all telephone connections in the MDU to connect through the VIS-3.
3. Locate the first appearance of the DAS Intercom telephone connection wall jack to the MDU. Rewire the connections so that the incoming wires from the DAS intercom are connected to pins 2 & 3 of the RJ-11 marked DAS/Intercom Input. Refer to Figure 2 for a rewiring example.

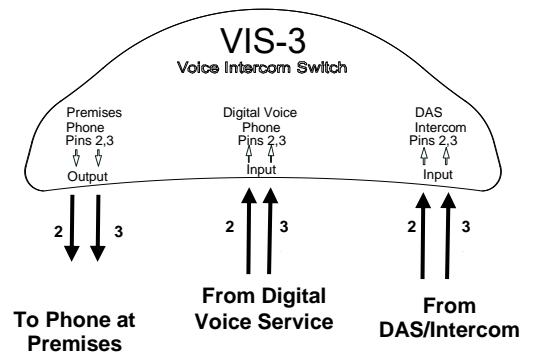

Figure 1

## Wiring

### Premise Phones

1. Plug one end of the RJ-11 cable to the phone at premises receptacle on the VIS-3. Connect the other end of the cable to the phone connection to the whole premises.

### Digital Voice Service Device

1. Plug one end of another RJ-11 cable to the Digital Voice Service receptacle on the VIS-3. Connect the other end to the RJ11 output from the voice output of ONT (Optical Network Terminal) (Figure 1).

### Intercom

1. Plug one end of the third RJ-11 cable to the DAS / Intercom receptacle on the VIS-3 (Figure 2).
2. Connect the other end of the cable to the rewired (Per Figure 2) intercom input.

## Testing

1. On power-up the unit is in Digital Voice Mode. The LED should start flashing within a few seconds of powering up (Figure 3).
2. The VIS-3 will automatically switch to DAS / Intercom Mode when the Local Digital Voice Service power is disconnected.
3. When the DAS / Intercom rings and the Digital Voice line is on hook, the VIS-3 will switch to the DAS / Intercom. After answering the intercom or the ringing has stopped, the VIS-3 will switch back to Local Digital Voice Service mode.
4. To answer the DAS / Intercom when the Digital Voice line is in use, press the flash hook switch momentarily, this will hold the Digital Voice line and at the same time switch the VIS-3 to DAS / Intercom mode.
5. When finished with the DAS / Intercom call, press the flash hook switch momentarily to recover the Voice line. In some case the flash switch may need to be activated twice to recover the voice line.

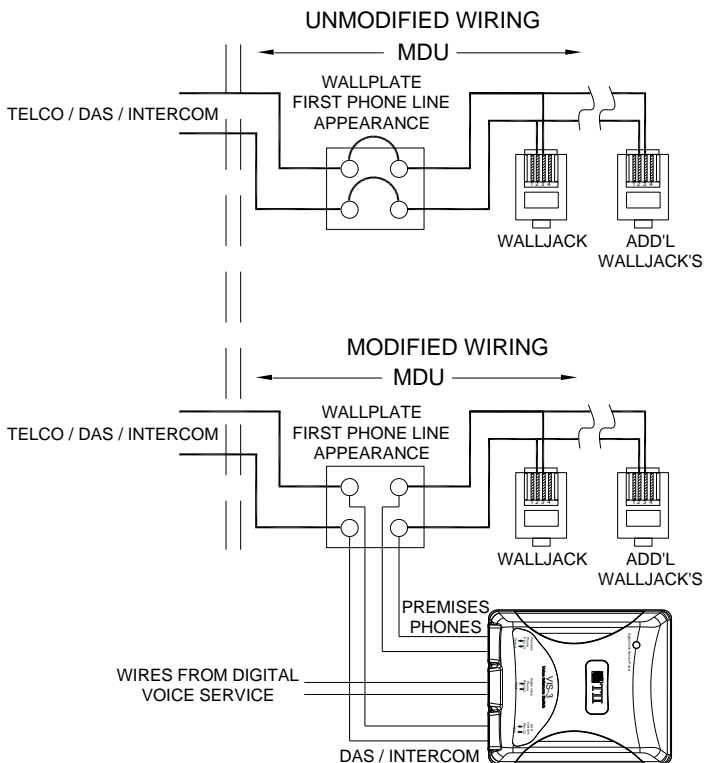

Figure 2