

INSTALLATION NOTE

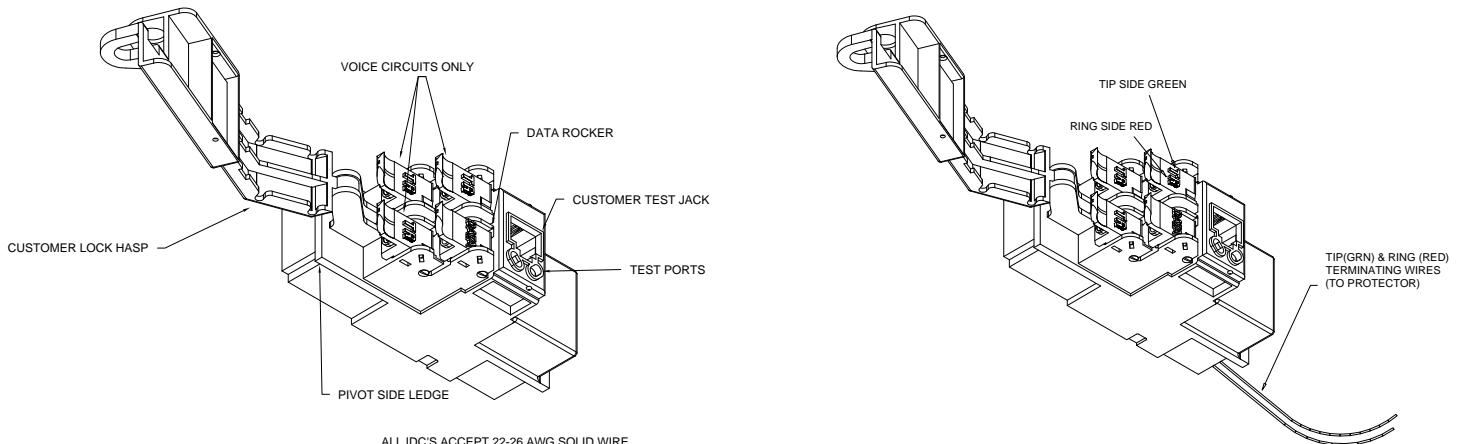

Figure 1

1.0 DESCRIPTION

1.1 The TII 96-00-5 Series VDSL2 Splitter Module maintains a constant direct connection between customer and central office service provider. The Splitter Module is equipped with a customer test jack (see Figure 1). The customer can insert the RJ-11 plug from a working telephone into this test jack to assure a signal is received from the central office. This is the only time the customer is disengaged (both DSL and POTS service) from the central office.

2.0 WARRANTY

2.1 See TII Warranty. If this unit fails during the warranty period, the factory should be requested to authorize return. Return the unit prepaid. Units that fail due to normal wear or abuse should be discarded.

3.0 INSTALLATION

- 3.1 Remove the Splitter Module from plastic bag and inspect; if damaged, replace with an undamaged Splitter Module.
- 3.2 Hold the Splitter Module with the cover pivot side on right.
- 3.3 Lower the pivot side edge inside the designated installation cavity.
- 3.4 Engage the right end ledge under the catch. (See Figure 2)
- 3.5 Push the left side end down until the latch snaps closed.

4.0 WIRING

- 4.1 Three telephone voice (POTS) pairs and one DSL line (DATA) can be connected to a single Splitter Module. The customer has the option of installing a #10 Master lock around the customer lock hasp (see Figure 1).
- 4.2 When installing the first pair of customer telephone wires, always begin with the bottom terminating rockers (see Figure 1).
- 4.3 Do not strip wire insulation from wires to be terminated to Splitter Module.

CAUTION: TO REDUCE THE RISK OF PERSONAL INJURY, INSERT A RJ-11 PLUG INTO THE CUSTOMER TEST JACK PRIOR TO MAKING ANY WIRING CONNECTIONS .

- 4.4 Dress terminating wires (to protector) over NID divider.
- 4.5 Insert and terminate TIP (GRN) & RING (RED) wires into sealed IDC station protector (see protector installation note for further details).
- 4.6 Open customer security cover on Splitter Module.
- 4.7 Lift all Splitter Module rockers to the open position as shown (see Figure 1).
- 4.8 Dress wires around customer security cover.
- 4.9 Start wiring from the bottom left rocker.
- 4.10 Hold the customer voice telephone wires between thumb and index finger (approx. 1/8" separation between wires).

NOTE: IDC's accept 22-26 AWG solid wire. Wires should be aligned to the corresponding holes. Green wire to the "T" (GRN) labeled wire guide and the Red wire to the "R" (RED) labeled wire guide.

- 4.11 Insert wires into wire guides at the same time until they bottom out.
- 4.12 While holding wires in wire guides, terminate rocker with thumb (lower rocker all the way).
- 4.13 Terminate additional voice pairs to lower right and upper left rockers as required.
- 4.14 Terminate the DSL customer wire pair at upper right locker only.
- 4.15 Assure all rockers are in the down position and close customer security cover.

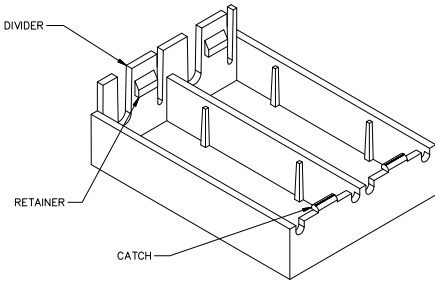

Figure 2

5.0 CUSTOMER TELEPHONE WIRE INTEGRITY TESTING

- 5.1 Open customer security cover.
- 5.2 Insert RJ-11 plug into customer test jack to isolate telco from customer wiring.
- 5.3 Lift all rockers to the up position.
- 5.4 Insert customer telephone wire into rocker wire guides as shown (see Figure 3).
- 5.5 Terminate rocker (lower rocker all the way).
- 5.6 Using an ohmmeter, insert probes into test ports as shown (see Figure 3), and check for continuity.
- 5.7 Customer wiring is ok if meter does not indicate a short circuit.
- 5.8 Repeat test for all four sets of customer telephone wires. If the customer telephone wire does not show a meter reading, then it has a break in it.
- 5.9 Close customer security cover and inform customer.

6.0 CENTRAL OFFICE SIGNAL TESTING

- 6.1 Open customer security cover.
- 6.2 Using a working telephone, insert telephone RJ-11 plug into customer test jack (see Figure 4).
- 6.3 Wait a few seconds, lift receiver, and listen for tone.
- 6.4 If tone is not present, then contact central office service provider.
- 6.5 If dial tone is present, then a problem exists in the customer telephone wires.

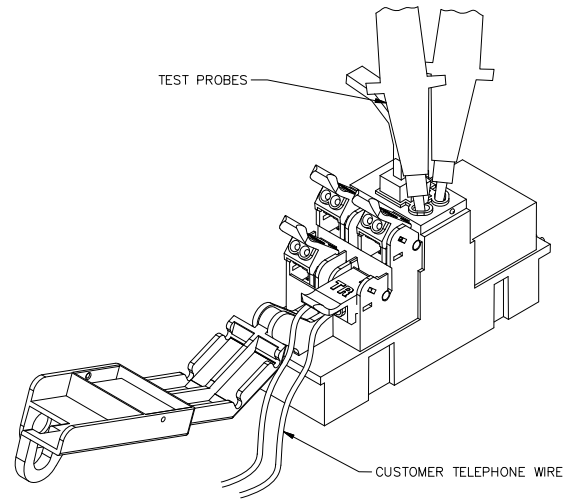

Figure 3

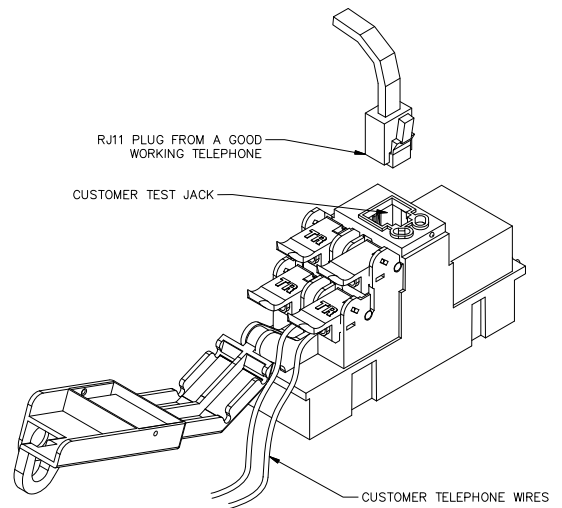

Figure 4